



## SWITCH® SHIELD PINSETTER

### USER MANUAL

v\_0001\_25



**Switch® International**

ITOB Organize Sanayi Bolgesi  
35477 Menderes Izmir / TURKEY

T: +90 232 799 0344

sales@switchbowling.com

**switchbowling.com**



## **Legal and Administrative Notices**

### **All Rights Reserved**

All rights to this manual, including the diagrams, figures, and technical specifications, are the property of Switch Bowling. Reproduction or transmission of any of the material contained in this manual without the prior written permission of Switch Bowling is strictly prohibited. All the product information in this manual was carefully prepared based on the latest information available and was believed to be correct at the time of printing. While every effort has been made to ensure accuracy, this publication may inadvertently contain typographical errors, inaccuracies, or omissions. Switch Bowling cannot be held responsible for any claims resulting from these errors.

### **Document Updates**

This manual supersedes all previous versions of the Switch® Shield String Pinsetter User Manual. Switch Bowling reserves the right to revise and/or update this manual at any time without obligation to notify any person or entity of such revision. The document number, revision level, and date below indicate the edition of this manual.

### **Trademark Notices**

Switch Bowling and the Switch Bowling logo are trademarks of Switch Bowling. Any other trademarks mentioned in this manual are the property of their respective owners.

### **Conditional Information**

This manual assumes that the Switch Bowling equipment and/or software has been installed by a Switch Bowling-authorized technician and is functional in every aspect. Should you encounter problems in operating the equipment, follow the instructions in this manual before contacting Switch Bowling for service under warranty.



## 1. Introduction

### About the Switch® Shield String Pinsetter

The Switch® Shield String Pinsetter represents a significant evolution in bowling technology. Designed for reliability, efficiency, and user-friendliness, this pinsetter offers a modern alternative to traditional mechanical systems. It reduces maintenance needs and enhances the bowling experience for both casual players and professionals.

The Switch® Shield is an ideal choice for bowling centers looking to reduce operational costs while maintaining a high-quality playing experience. Its advanced string technology ensures precise pin handling and consistent performance, setting it apart from conventional pinsetters.

### Key Features

- **Durability:** Built with reinforced materials to ensure longevity and withstand continuous operation.
- **Energy Efficiency:** Reduces power consumption while maintaining peak performance, lowering utility costs for operators.
- **Ease of Use:** User-friendly control interface with wireless connectivity options for easy monitoring and adjustments.
- **Compliance:** Certified by IBF and USBC for professional use, ensuring it meets industry standards for competition.
- **Advanced Diagnostics:** Built-in tools for real-time fault detection and troubleshooting.

### Compliance and Certifications

This pinsetter meets all regulatory standards for safety and competition. It is compliant with:

- **International Bowling Federation (IBF):** Ensuring compatibility with international competitions.



- **United States Bowling Congress (USBC):** Valid for use in certified league and tournament play.

## 2. Safety Guidelines

### General Safety Precautions

The Switch® Shield String Pinsetter is designed with operator safety in mind. However, adherence to safety protocols is essential to prevent accidents:

- Always turn off power before servicing the machine.
- Never operate the pinsetter without proper training.
- Ensure all safety guards are securely in place before use.
- Avoid standing near moving parts during operation.
- Do not tamper with or bypass safety mechanisms.

### Operator Safety Requirements

Operators should:

- Wear personal protective equipment (PPE) such as gloves, safety goggles, and non-slip footwear.
- Maintain a clear work area around the machine to prevent tripping hazards.
- Avoid wearing loose clothing or accessories that could get caught in moving parts.
- Follow the manufacturer's guidelines for safe operation and maintenance.

### Emergency Procedures

- **Emergency Stop:** Locate and familiarize yourself with the emergency stop buttons on the control panel.
- **Power Shutdown:** Disconnect the main power supply in case of severe malfunctions or emergencies.
- **Technical Support:** Contact support immediately if the machine exhibits unusual behavior that cannot be resolved.



### 3. Product Overview

#### Main Components

The Switch® Shield String Pinsetter includes the following key components:

1. **Frame Structure:** Provides structural support for the entire system, ensuring stability and durability.
2. **String Mechanism:** Handles pin resetting with high precision and minimal wear.
3. **Pin Table:** Aligns and positions pins accurately for consistent setup.
4. **Control Panel:** Allows operators to manage settings, monitor performance, and access diagnostic tools.
5. **Ball Return System:** Ensures smooth and efficient ball retrieval for uninterrupted gameplay.
6. **Safety Guards:** Protect operators from moving parts and reduce the risk of injuries.

#### String Pinsetting Technology

Unlike traditional mechanical pinsetters, the string mechanism uses high-tensile strings to reset pins. This reduces mechanical complexity and maintenance needs, while also providing quieter operation and greater reliability. The strings are designed for long-term use, minimizing replacement frequency.

#### Control System Features

- **Touchscreen Interface:** Offers intuitive controls for adjusting settings, selecting modes, and accessing maintenance logs.
- **Wireless Connectivity:** Enables remote diagnostics, real-time updates, and performance monitoring.
- **Fault Detection:** Alerts operators to mechanical or electrical issues, allowing for prompt resolution and minimal downtime.



## 4. Installation and Setup

### Pre-Installation Requirements

Before installing the Switch® Shield String Pinsetter, ensure the following:

- **Space Requirements:** Verify that the bowling lane area meets the recommended dimensions for the pinsetter. A minimum of 3 meters behind the pin deck is required for proper installation.
- **Power Supply:** Ensure the venue's electrical system provides a voltage range of 205-380V Three Phase and frequency of 50/60Hz.
- **Tools Needed:** Prepare the following tools: socket wrenches (M8, M10, M16), screwdrivers, measuring tape, and a level.

### Assembly Steps

#### Step 1: Frame Assembly

- Begin by attaching the left and right panels to the base frame using the M16 adjustable legs.
- Secure the bottom fixing profile with M8 bolts to stabilize the structure.

#### Step 2: Back Cover Installation

- Align the back cover with the frame and use side hooks to attach it to the top panel slots.
- Tighten all connections with M8 fiber nuts to ensure stability.

#### Step 3: Pin Deck Installation

- Position the pin deck on the frame, ensuring it aligns with the support brackets.
- Secure it using M10 bolts, checking alignment with a level to avoid misconfiguration.



#### **Step 4: Electrical Connections**

- Connect the main power cable to the control box and secure all wiring with clamps to prevent accidental disconnection.
- Test the power supply to ensure proper voltage and grounding.

#### **Step 5: Calibration**

- Power on the system and follow the on-screen prompts for calibration.
- Adjust string tension and pin alignment to achieve optimal performance.

#### **Electrical and Network Setup**

- Connect the pinsetter to the venue's network for remote diagnostics and updates.
- Configure wireless settings through the control panel to enable remote monitoring.

### **5. Operation Instructions**

#### **Starting the Pinsetter**

1. Ensure all components are properly assembled and secured.
2. Turn on the main power supply and wait for the system's initialization sequence to complete.
3. Access the control panel and select the desired operating mode.

#### **Operating Modes**

- **Standard Play Mode:** For regular bowling games with automatic pin resetting.
- **Training Mode:** Allows for customizable pin setups, ideal for practice and skill development.
- **Competition Mode:** Configures the system for professional-level gameplay with precise alignment and timing.



## Real-Time Monitoring and Adjustments

Use the touchscreen control panel to:

- Monitor system performance metrics, including cycle times and fault logs.
- Adjust string tension, pin placement, and other parameters.
- Access real-time diagnostic tools for troubleshooting.

## 6. Maintenance Schedule

### Daily Maintenance

- Inspect strings for signs of wear or fraying. Replace if necessary.
- Clean the pin table and ball return track to remove dust and debris.
- Verify that all safety guards are intact and functional.

### Weekly Maintenance

- Lubricate moving parts, such as the string pulleys and alignment mechanisms, using manufacturer-recommended lubricants.
- Test the emergency stop functionality to ensure it operates correctly.

### Monthly Maintenance

- Replace worn strings and rubber components as needed.
- Perform a comprehensive inspection of all electrical connections to ensure stability.
- Update the system firmware to incorporate the latest features and fixes.

## 7. Troubleshooting

### Common Issues and Solutions

- **Machine Fails to Start:** Check the power supply and emergency stop switches. Ensure all connections are secure.
- **Uneven Pin Setup:** Adjust string tension and inspect for obstructions in the pin table.



- **Ball Return Malfunction:** Clear debris from the return track and verify alignment of the ball lift mechanism.

### Diagnostic Tools

- Access the built-in diagnostic menu on the control panel for detailed error codes and suggested resolutions.
- Use the wireless connectivity feature to receive remote assistance from technical support.

### 8. Technical Specifications

- **Dimensions:** Width - 200cm, Height - 150cm, Depth - 300cm
- **Weight:** 250kg
- **Power Requirements:** 205-380V Three Phase, 50/60Hz
- **Materials:** Steel frame, high-tensile strings, composite pin table
- **Compliances:** IBF and USBC

### 9. Warranty and Support

#### Warranty Terms

The Switch® Shield String Pinsetter is covered by a 1-year limited warranty. This includes manufacturing defects and system failures under normal use.

#### Contacting Technical Support

- **Phone:** +90 232 799 03 44
- **Email:** info@switchbowling.com
- **Website:** switchbowling.com

### 10. Appendix

#### Glossary of Terms

- **Pin Deck:** The area where pins are set up.
- **String Mechanism:** The system of strings used to control pin resetting.



- **Ball Return System:** Mechanism that retrieves and delivers the ball back to the player.

## Parts Diagram

### Shield Backend Even

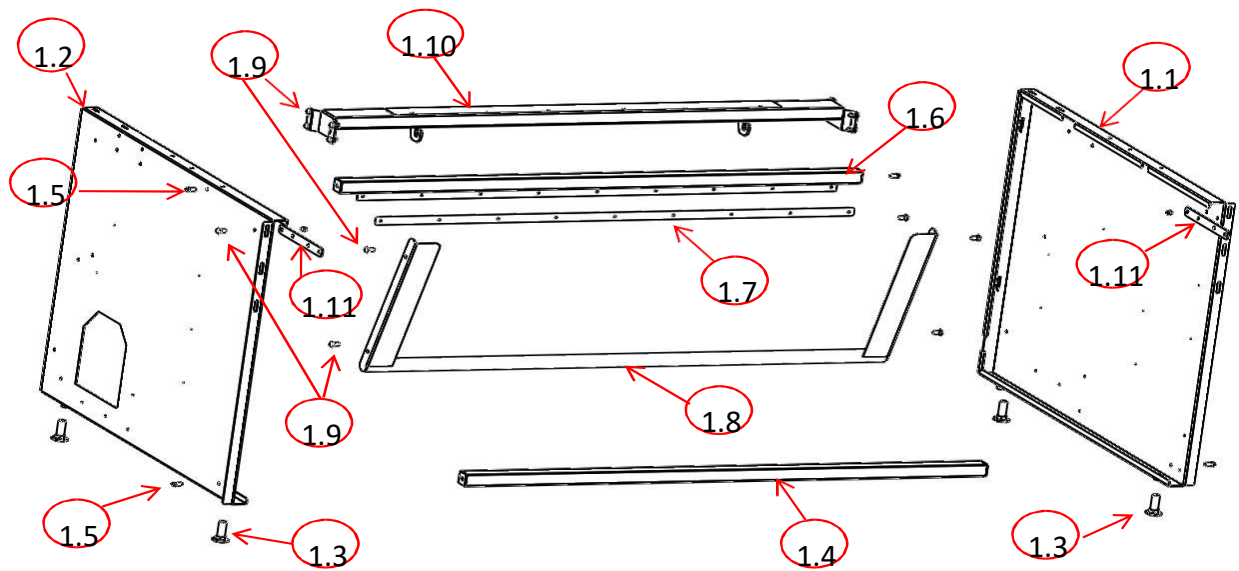

- 1.1 - Right panel: 2 PCS M16 adjustable legs (1.3) are connected to the lower part.
- 1.2 - Left panel: 2 pcs M16 adjustable legs (1.3) are connected to the lower part.
- 1.4 - Bottom fixing profile: tightened with 2 pcs M8x20 AKB bolts (1.5)
- 1.6 - Upper fixing profile (curtain hanger profile): Tightened with 2 pcs M8x20 AKB bolts
- 1.7 - Curtain tightening sheet: Tightened with 9 pcs M6x16 Allen bolts and M6 fiber nuts.
- 1.8 - Rubber stopper group: 4 PCS of M8x20 YB are connected with a square bolt (1.9) and an M8 fiber nut at the bottom.
- 1.10 - Rubber hanger group: 8 pieces of M8x20 YB are connected to the bottom with a square bolt (1.9) and an M8 fiber nut.



1.11 - Wooden connection bracket (2 pcs): Each M8x20 YB is connected with a square bolt (1.9) and an M8 fiber nut at the bottom.

*Product Assy.*

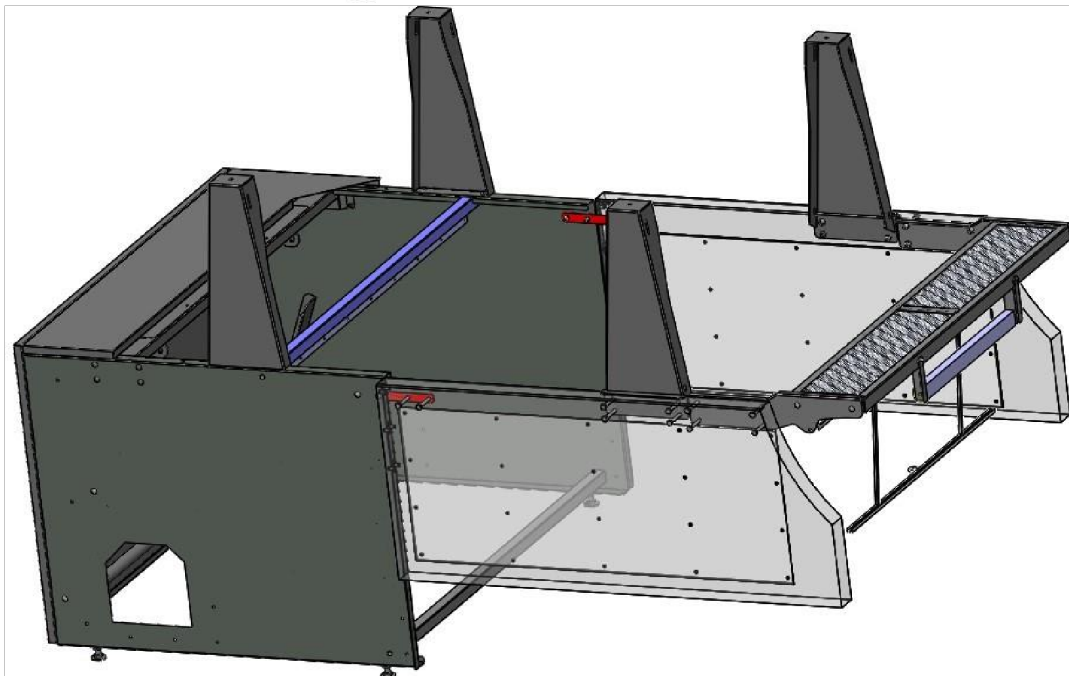
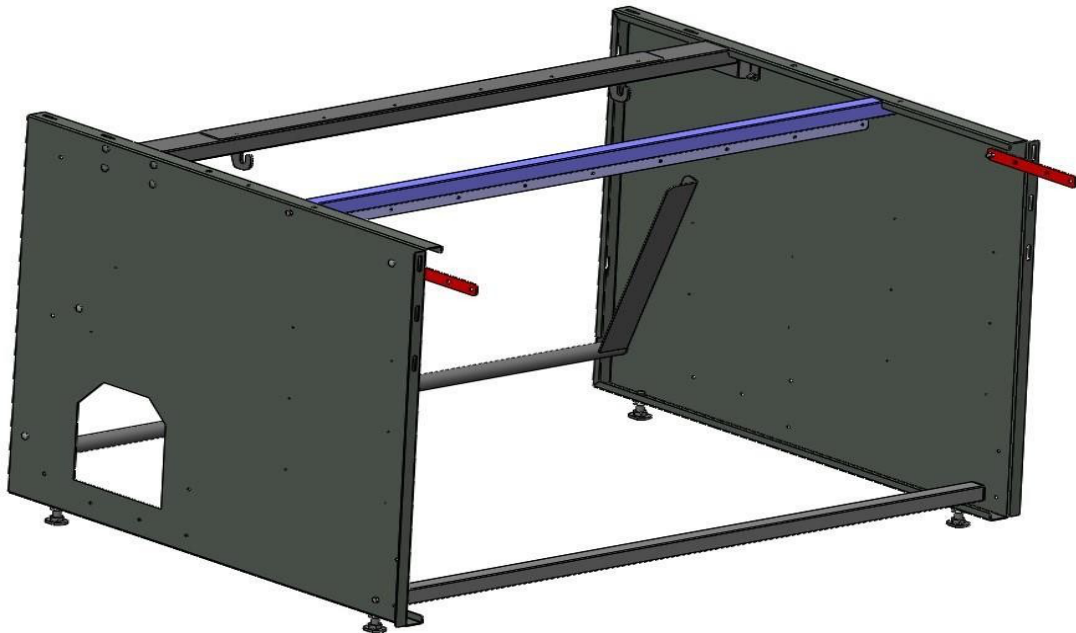

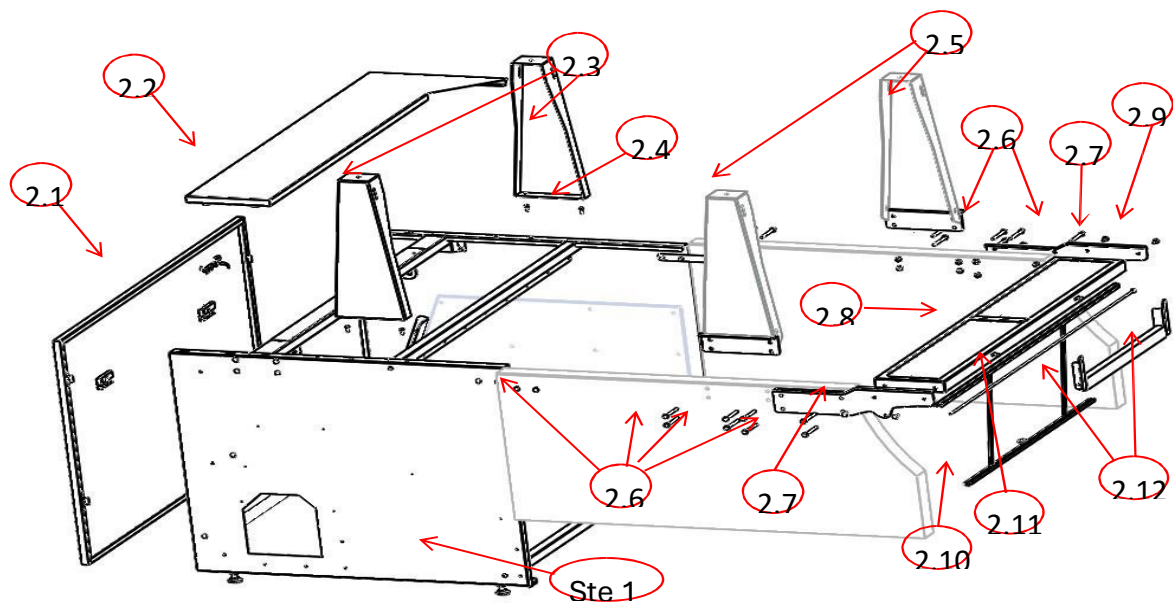

2.1 - Back cover: four hooks on the sides are attached from the top down to the slots on the Right/Left panels.

2.2 - Top L cover: four hooks on the sides are attached to the slots on the Right/Left panels by pushing from the back to the front.

2.3 - Rear support sheet: It is connected to the side panels with 2 pcs M8 x 20 AKB (2.4) and M8 fiber nuts.

2.5 - Front support sheet: It is connected to 70 mm wooden panels with 4 PCS M10x90 AKB (2.6) and M10 fiber nuts.

2.7 - Step support sheet (right/left): It is connected to 70 mm Wooden Panels with 4 M10x90 AKB (2.6) and M10 fiber nuts.

2.8 - Step group: 4 pieces of M8x20 YB are connected to the bottom with a square bolt (2.9) and an M8 fiber nut (2.7)

2.10 - SHIELD panel frame: It is installing on (2.7) with axis wire (2.11) and a 3.5 x 20 mm joiner pin is attached to the wire end.

2.12 - Lamp sheet (Right/Left): Installed with 1 pcs M6x16 inbus and M6 fiber nut (2.8).

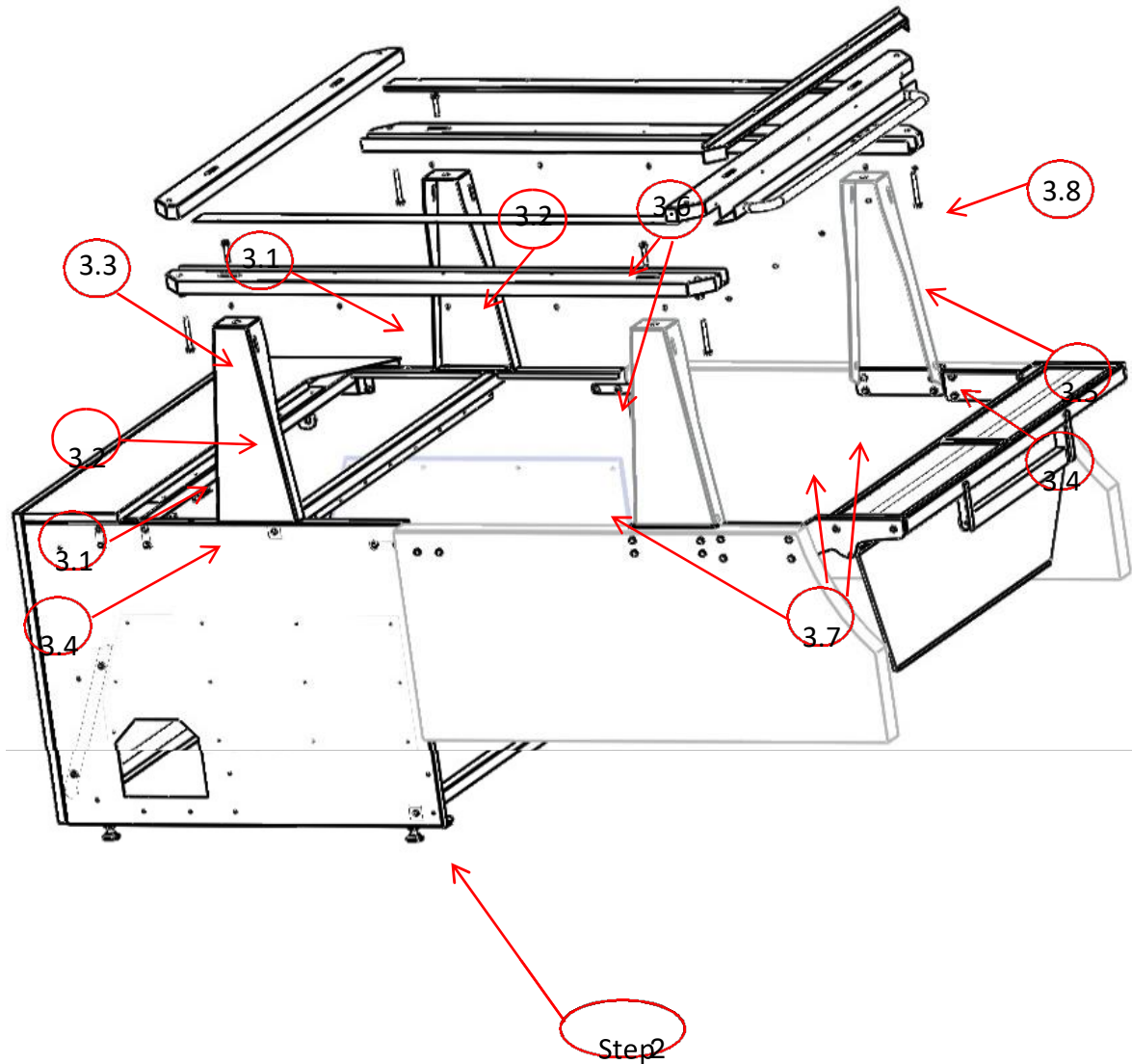

3.1 - U vessel side: M10x60 AKB bolt (3.2) is tightened to the support sheets with an M10 fiber nut and 2 M10 washers.

3.3 - U vessel rear: M10x100 AKB is tightened to (3.1) with bolt (3.4), M10 fiber nut and 2 PCS of M10 washer.

3.5 - U vessel front: tightened to (3.1) with M10x100 AKB bolt (3.4), M10 fiber nut and 2 pieces of M10 washer.

3.6 - Cable vessel cover side (2 pcs) : 4,2x16 is tightened to (3.1) with YSB sheet screw (3.7).

3.8 - Cable vessel cover front: 4,2x16 is tightened to (3.5) with YSB sheet screw (3.7).

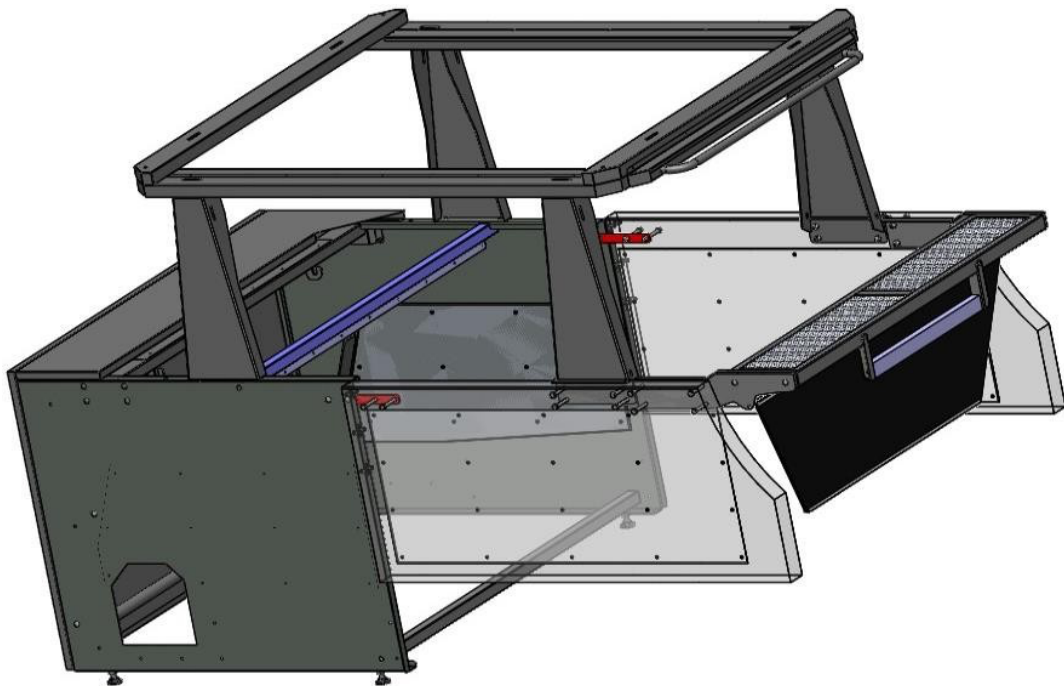

## **Switch Shield Control Box**

### **Introduction**

The Switch Shield Control Box is designed to manage and optimize the operation of string bowling machines. This system provides seamless communication between the machine and the server, ensuring smooth gameplay and high reliability.

### **Features**

The Switch Shield Control Box serves as the primary control unit for string bowling machines, processing commands and enabling automation.

### **Key Features:**

**Modular Structure:** Can be customized according to user requirements.

**Machine Compatibility:** Fully compatible with SES-branded string bowling machines.

**High Reliability:** Designed for 24/7 operation with a high Mean Time Between Failures (MTBF).

### **Integrated Features:**



- Direct Ethernet connection
- Wi-Fi tablet control
- **Switch Care** support
- Integrated bumper output
- Integrated table lighting
- Multi-protocol support
- Isolated machine connections

### **Electrical Connections**

The control box supports multiple inputs and outputs, allowing seamless integration with system components.

#### **Main Power Inputs:**

Line 1 (R), Line 2 (S), Line 3 (T) – Main power phases

Neutral & Earth – Safety grounding and voltage stabilization

#### **Motor Connections:**

Elevator Motor – 24V DC (OC Mosfet Out)

Ball Lift Motor – 24V DC (OC Mosfet Out)

String Motor – 24V DC (DC Contactor Control)

#### **Sensor Interfaces:**

Ball Sensor (Odd & Even Lanes) – 12V powered detection

Foul Sensor (Odd & Even Lanes) – Standard Bitfoul connection

Emergency Stop Button – Safety cut-off mechanism

#### **Lighting Outputs:**

RGB LED Outputs (Odd & Even lanes) – 24V DC

Table LED Light – 12V DC

Pit Light Output – Light/Glow Out (NOC)

#### **Additional Interfaces:**

Buzzer Output – Warning alerts



<b>Storage Temperature</b>	-40°C ~ 60°C
<b>Humidity</b>	90% Max
<b>Shock Resistance</b>	10g, 11msec
<b>Dimensions</b>	200mm x 145mm
<b>Material</b>	FR4-6 Layer (ROHS Compliant)

### Installation & Maintenance

#### Installation Guidelines:

Ensure all power and data connections are properly secured.

Verify power input before activating the system.

#### Troubleshooting:



No Power: Check input voltage and ensure the main breaker is active.

Sensor Malfunction: Inspect connections and test signal continuity.

LED Malfunction: Verify RGB connections and power output.

Wi-Fi/Ethernet Issues: Reset network settings and check for proper configurations.

### Electrical Connection Details

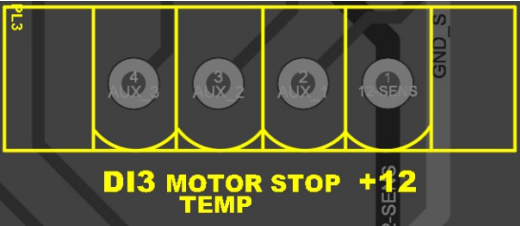
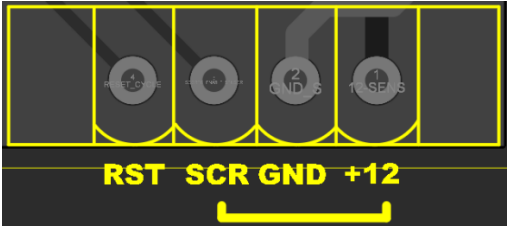
 <p><b>GND BUZ SIG +12</b></p>	 <p><b>GND SIG +12</b></p>
 <p><b>DI3 MOTOR STOP +12 TEMP</b></p>	 <p><b>RST SCR GND +12</b></p>
<p>PL3-Foul Censor</p>	<p>PL4-Ball Censor</p>
<p>PL10-Motor Stop</p>	<p>PL5-Control Input</p>

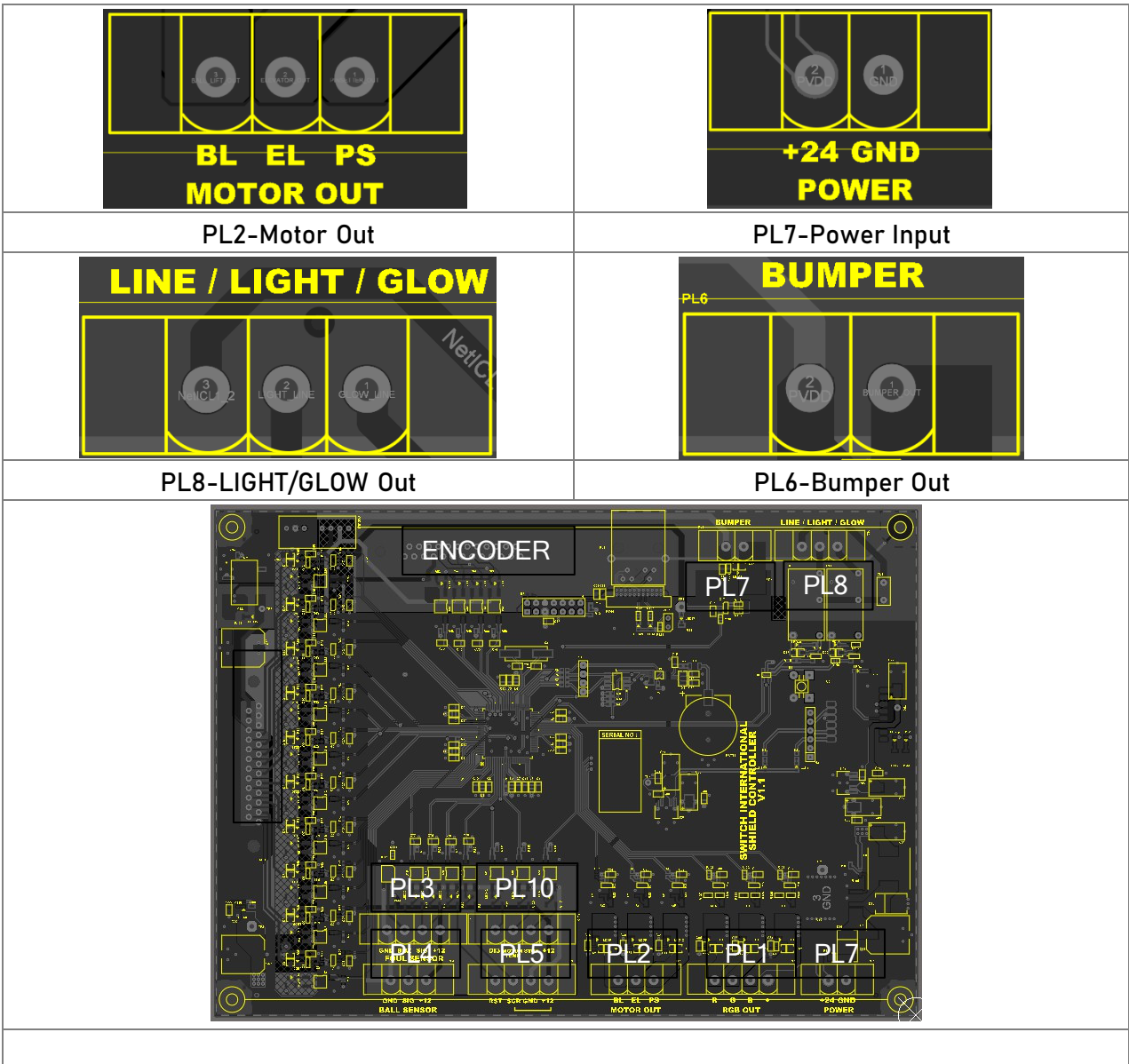

**Conclusion**

The Switch Shield Control Box provides a comprehensive solution for automated bowling operations, offering high reliability, modular adaptability, and seamless connectivity. It ensures safe and efficient power distribution, making it an essential component of the system.

This user manual is designed to guide you through the installation, operation, and maintenance of the Switch® Shield String Pinsetter, ensuring a seamless and efficient experience.